



UNCLASSIFIED CHAIRMAN OF THE JOINT CHIEFS OF STAFF INSTRUCTION

J-4

DISTRIBUTION: A, B, C

CJCSI 4310.01E

13 January 2020

LOGISTICS PLANNING GUIDANCE FOR PRE-POSITIONED WAR RESERVE MATERIEL

References: See Enclosure G

1. Purpose. This instruction establishes logistics planning guidance for pre-positioned war reserve materiel (PWRM) for use during a full spectrum of contingency operations during peacetime or wartime periods, as defined in reference a.
2. Superseded/Cancellation. CJCSI 4310.01E, 30 December 2016, "Logistics Planning Guidance for Global Pre-positioning Materiel Capabilities," is hereby superseded.
3. Applicability. This instruction applies to the Services, Combatant Commands (CCMDs), and the Joint Staff.
4. Policy. This instruction articulates procedures for the development and the management of PWRM, which includes all pre-positioned war reserve capabilities and pre-positioned war reserve stocks. Pre-positioning ships are apportioned per reference b to Combatant Commanders for full-spectrum adaptive planning. The Secretary of Defense (SecDef) authorizes the release of PWRM to an allocated force for operational employment.
5. Definitions. See Glossary.
6. Responsibilities. Responsibilities are listed in Enclosure A.
7. Summary of Changes. This instruction further defines PWRM and introduces sub-categories of pre-positioned war reserve capabilities and pre-positioned war reserve stocks; provides a joint strategy for PWRM; refines the responsibilities of the Joint Staff, Services, and the CCMDs; and emphasizes the authorization for use of PWRM as directed by references b, c, or by higher authority and reporting requirements as directed by references d, e, and f or by higher authority.

UNCLASSIFIED

UNCLASSIFIED

CJCSI 4310.01E
13 January 2020

8. Releasability. UNRESTRICTED. This directive is approved for public release; distribution is unlimited on NIPRNET. DoD Components (to include the CCMDs), other Federal agencies, and the public, may obtain copies of this directive through the Internet from the CJCS Directives Electronic Library at <<http://www.jcs.mil/library>>. Joint Staff activities may also obtain access via the SIPR directives Electronic Library websites.

9. Effective Date. This INSTRUCTION is effective upon receipt.

For the Chairman of the Joint Chiefs of Staff:



WILLIAM D. BYRNE, JR., RADM, USN
Vice Director, Joint Staff

Enclosures

- A - Pre-positioned War Reserve Materiel Strategy
- B - Guidance for the Employment of Pre-Positioned War Reserve Materiel
- C - Message Format for Use of Pre-positioned War Reserve Materiel for Training/Exercises
- D - Memorandum for the Operational Employment of Equipment
- E - Memorandum for the Reassignment of Pre-Positioning Ships
- F - Memorandum for the Modification of a Service PWRM Program
- G - References
- GL - Glossary

UNCLASSIFIED

CJCSI 4310.01E
25 November 2019

TABLE OF CONTENTS

| | Page |
|--|------|
| ENCLOSURE A | |
| Pre-positioned War Reserve Materiel Strategy | A-1 |
| ENCLOSURE B | |
| Guidance for the Employment of Pre-positioned War Reserve Materiel | B-1 |
| ENCLOSURE C | |
| Memorandum for the Operational Employment of Equipment | C-1 |
| ENCLOSURE D | |
| Memorandum for the Reassignment of Pre-positioning Ships | D-1 |
| ENCLOSURE E | |
| Memorandum for the Modification of a Service PWRM Program | E-1 |
| ENCLOSURE F | |
| Message Format for the Use of Pre-positioned War Reserve Materiel for Training/Exercises..... | F-1 |
| ENCLOSURE G - REFERENCES | G-1 |
| GLOSSARY | GL-1 |

UNCLASSIFIED

CJCSI 4310.01E
25 November 2019

(INTENTIONALLY BLANK)

UNCLASSIFIED

UNCLASSIFIED

CJCSI 4310.01E
25 November 2019

ENCLOSURE A

PRE-POSITIONED WAR RESERVE MATERIEL STRATEGY

1. Background

a. Geographic Combatant Commands (GCCs) use the National Security Strategy, National Military Strategy, Defense Planning Guidance, the Global Force Management Implementation Guidance (GFMIG), and the Joint Strategic Campaign Plan (JSCP) to identify force requirements when developing campaign plans. To expedite force closure in response to global contingencies, campaign plans must include planning for and use of Service PWRM programs.

b. PWRM refers to war reserve materiel strategically located to facilitate a timely response in support of Combatant Commander (CCDR) requirements during initial phases of an operation. To respond quickly to requirements, Services shall size, manage, and pre-position resources in a GCC area of responsibility (AOR). Pre-positioning provides the greatest practicable flexibility to respond to a spectrum of regional contingencies while reducing the demand on the global transportation network.

c. Pre-positioned war reserve capabilities (PWRC) (ashore and afloat) place equipment and supplies at or near the point of planned use to reduce reaction time and ensure timely support of a specific force during the initial phases of an operation. These assets provide CCDRs with initial capabilities and materiel until establishment of a mature and sustained Strategic/Theater Distribution Network.

d. Services support GCC requirements by pre-positioning capabilities, forces and equipment, to support global requirements. Services take into account strategic direction, national security threats, strategic mobility, and GCC requirements to determine the size, composition, and positioning of PWRM.

e. The Services plan, program, budget and execute to the most demanding contingency plans (CONPLANS) to identify the pre-positioning requirements, derived from integrated planning and aligned with the top priority plans listed in the JSCP and joint mobilization plans. PWRM capabilities and stocks enable prompt and sustained combat operations on air, land, and/or at sea.

f. Considering the cost of establishing and maintaining Service pre-positioned capability programs, DoD and the Joint Staff continue to analyze and refine the recommendations through Mobility Capability and Requirements

UNCLASSIFIED

UNCLASSIFIED

CJCSI 4310.01E
25 November 2019

Studies and Mobility Capabilities Assessments.

2. Purpose. To provide guidance for the oversight of the Service PWRM programs in order to achieve an efficient, coordinated, and agile materiel response in support of one or multiple GCCs.

3. Process

a. All Service PWRM programs require joint alignment with National priorities and GCC requirements across the full range of military operations. Appropriate positioning and composition of PWRM:

- (1) Maximizes warfighter support.
- (2) Achieves the greatest agility for rapid deployment and distribution.
- (3) Reduces reaction time.
- (4) Supports forces worldwide in the initial phases of operations.
- (5) Minimizes DoD expenses.

b. PWRM planning involves a process to determine the composition and the geographical location of the materiel to support GCC requirements spanning the range of military operations.

c. Pre-positioned war reserve requirement (PWRR) is the materiel requirement established by the Services (or Service components) and assessed through operational planning, identified for a specified force's requirement, and positioned at or near the point of use to support a specified plan or contingency. PWRR recognizes GCC Service component's PWRM requirements, in accordance with the DPG, the GFMIG, and the JSCP, for assigned/apportioned forces to support the campaign plans in a resource-informed environment. PWRR identifies the minimum PWRM. However, the Services determine the size and composition of the Service's PWRM, above the PWRR minimum, required to satisfy the most demanding operations plan (OPLAN)/CONPLAN requirements.

d. GCC Service components determine PWRM requirements—GCCs validate the requirement and the Services review the GCC's requirement to determine supportability based on current force structure and availability of materiel and equipment. The Services develop their PWRM strategy and plan to fill the GCC's requirement. However, supporting multiple OPLANs/CONPLANs

UNCLASSIFIED

UNCLASSIFIED

CJCSI 4310.01E
25 November 2019

may require the same capabilities and stocks. Any identified shortfalls in PWRM requirements will include a mitigation plan to reduce the operational risk of the PWRM shortfall. To address shortfalls, Services/GCC(s) may submit issue nominations for inclusion into the Service Program Objective Memorandums.

e. Services consider doctrine, organization, training, materiel, leadership and education, personnel, and facilities when determining the composition and positioning for pre-positioned materiel. Additionally, Services shall consider the following elements of logistics support analysis when identifying their PWRRs:

- (1) Access, basing, and overflight rights.
- (2) Force requirements and sourcing.
- (3) Verification of sustainment.
- (4) Analysis of transportation.
- (5) Assessment of networks and distribution network limitations.
- (6) Logistics support refinement.
- (7) Commodity distribution concepts.
- (8) Force protection, both active and passive measures.
- (9) Retrograde planning.
- (10) Reset planning.
- (11) Host Nation requirements.
- (12) Time to deploy.

f. This process takes into consideration the positioning of available PWRM ashore or afloat, host-nation agreements, space requirements, maintenance costs, contractual agreements, and security clearance requirements for host-nation maintenance support. Additionally, consideration to position Service PWRM afloat provides flexibility to respond to an area of concern with a capability to conduct instream or host nation port offload.

g. The Joint Staff views PWRM in a global context, taking into account

UNCLASSIFIED

CJCSI 4310.01E
25 November 2019

Service responsibilities under title 10, U.S. Code, and identifies gaps or potential efficiencies while maintaining operational flexibility. The PWRM strategy includes pre-positioned war reserve capabilities and pre-positioned war reserve stocks to execute campaign plans.

(1) PWRC include a force structure's equipment set that when combined with Service's personnel provides a warfighting capable of supporting a GCC's requirement.

(2) Pre-positioned war reserve stocks (PWRS) are stockpiles of materiel (ashore and afloat) based on an operational plan or theater requirement available to support military operations.

h. While PWRR identifies the minimum PWRM, the Joint Staff conducts an assessment and analysis to determine the effectiveness of the requirement. PWRM includes PWRC and PWRS. Shortfalls in PWRC or PWRS require a mitigation strategy coordinated between the Service and Service component.

i. The Joint Staff and/or the SecDef may allocate PWRM to support requests from GCC(s) expediting the force closure to execute operations throughout the range of military operations. Forces are apportioned and allocated; however, the PWRC is authorized for the allocated forces through a deployment or execution order (DEPORD/EXORD) for use. PWRS is not assigned or apportioned but Service/Agency managed; however, the pre-positioning ships with associated PWRM are apportioned for CCDR's planning.

j. The Services identify the PWRM support to a GCC providing an agile response to contingencies that may occur. Mitigation strategies may include global stocks or afloat PWRC that may be directed to support a CCDR AOR by the authorization of the SecDef.

k. Approval using the Global Defense Posture process may be required to establish new PWRM. The scope, scale, and policy significance of a location—as well as military construction, host-nation agreement, and personnel requirements—will determine the level of coordination required for SecDef approval. As required, Services and CCMDs will submit an Overseas Force Structure Change (OFSC) and Host Nation Notification (HNN) request to the Joint Staff J-5 in accordance with reference g. Chart 1 provides a flow chart for establishing a new PWRM requirement in an existing location and chart 2 for a new location.

New PWRM Requirement in an Existing Location

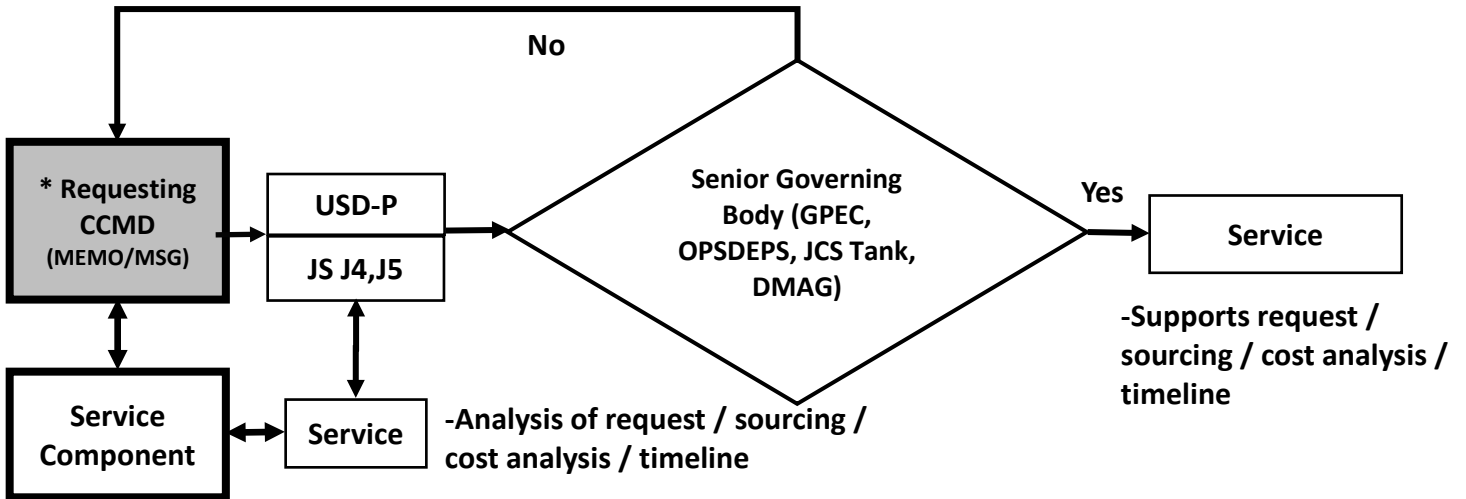

Chart 1

New PWRM Requirement in a New Location

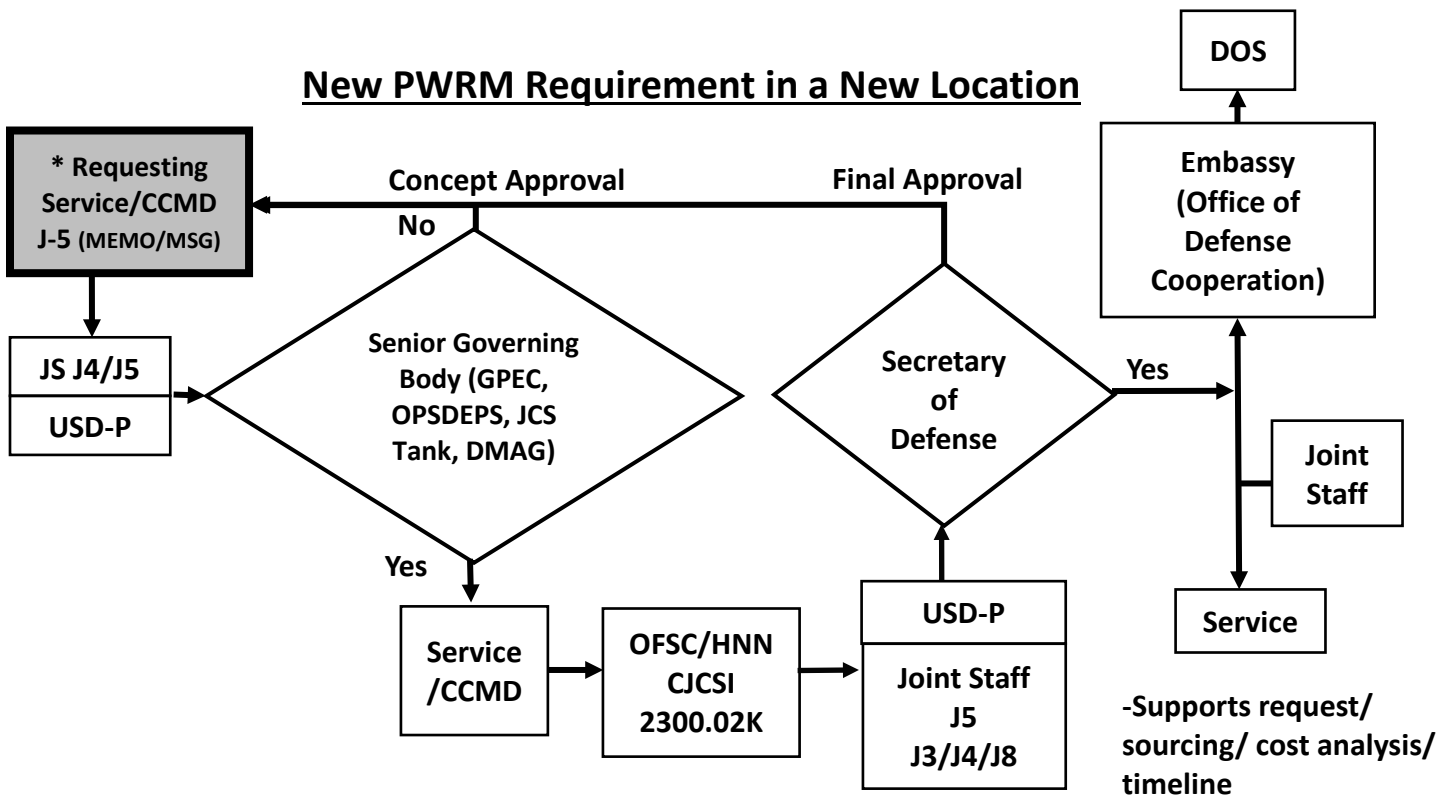

Chart 2

UNCLASSIFIED

CJCSI 4310.01E
25 November 2019

4. Responsibilities

a. Joint Staff. Joint Staff/J-4 will:

- (1) Validate the PWRM requirements of the GCC.
- (2) Assess the Service PWRM programs to efficiently support the GCC operational and regional strategies and plans while reducing duplicative capabilities and stocks in a GCC AOR.
- (3) Advise the SecDef on appropriate measures to reduce risk associated with any PWRM readiness changes that affect the ability to support GCC requirements.
- (4) Coordinate with the Under Secretary of Defense for Acquisition and Sustainment in establishing the Global Pre-positioned Materiel Capabilities Working Group (GPMCWG). The GPMCWG may develop sub-working groups to recommend policy, resolve Joint PWRM issues, provide information sharing, and provide oversight of the PWRM programs.
- (5) Develop a framework for joint oversight processes for synchronizing Services' pre-positioning strategies to minimize potential duplicative efforts, maximize efficiencies, and return on investment for PWRM.
- (6) Provide oversight of the Service PWRM programs. This includes ensuring the Services meet specified readiness reporting included in paragraph 5 of Enclosure A.
- (7) Identify, assess, and recommend measures to ensure the Service programs support GCC requirements in joint and combined operations environment.
- (8) Address joint issues concerning PWRM requirements, positioning, and recommendations for changes to Service programs.
- (9) Report annually on the status of prepositioned stocks to the congressional defense committees in accordance with title 10, U.S. Code, section 2229a.

UNCLASSIFIED

CJCSI 4310.01E
25 November 2019

b. Combatant Commanders

(1) Determine PWRM operational requirements consistent with strategic direction. A GCC must validate the operational requirement for Service PWRM as required by Service components.

(2) Validate Service component requirements and request PWRM in accordance with this instruction.

(3) Consider the use of PWRM positioned in or near their theater of operations for contingencies, exercises, and training. Enclosure B provides amplifying guidance on the process for requesting the use of PWRM.

(4) Conduct an operational risk assessment that evaluates the ability of the Services to meet the requirements and objectives stipulated in the Joint Strategic Campaign Plan.

(5) Incorporate pre-positioned assets and locations into their overall global posture planning, e.g., integrating these capabilities into contingency plans as flexible deterrent options.

(6) Include PWRM into OPLAN and Time Phased Force Deployment Data (TPFDD) development.

(7) Ensure that Active component forces are identified, sourced, and aligned against early PWRM requirements during OPLAN and TPFDD development.

(8) Identify to the Joint Staff any changes, additions, or deletions recommended by the Service component using Enclosure F for notification and/or approval. Paragraph 3 and chart 1 and 2 of this enclosure identify the process to request Service PWRM programs for new or existing locations. The process for recommending changes to the Service PWRM programs is located in chart 5, paragraph 3.b.(2) in Enclosure B.

(9) Report the status of PWRM in accordance with paragraph 5, Enclosure A.

c. Services

(1) Operate and administer PWRM in accordance with this instruction.

UNCLASSIFIED

CJCSI 4310.01E
25 November 2019

(2) Consider the use of PWRM positioned in or near their theater of operations for contingencies, exercises, and training. Services shall notify the Joint Staff J-4 when planning to use PWRM. Enclosure B, paragraph 3.c. identifies the process of notification for the use of PWRM for exercises.

(3) Manage the PWRM program to support the GCC based on the required organizational structure of forces and modify the program to respond to changes in the strategic environment by setting priorities for sizing and shaping the force, guiding the development and sustainment of capabilities and allocating resources.

(4) Ensure pre-positioning programs support the DoD's strategic guidance.

(5) Identify to the Joint Staff any recommended changes, additions, or deletions for notification and/or approval. Paragraph 3 and chart 1 of this enclosure identify the process to request Service PWRM programs for new or existing locations. The process for recommending changes to the Service PWRM programs is located in paragraph 3.b.(2) and chart 5 in Enclosure B.

(6) Report the status of PWRM in accordance with paragraph 5 in Enclosure A.

5. Reporting Requirements

a. Services will monitor and report readiness of Service PWRM programs in accordance with references d, e, and f.

(1) The readiness report includes the supply rating and the maintenance readiness rating of equipment organized around unit type equipment for an organized type force structure based on the program objective.

(2) PWRM with Unit Identification Code (UIC) that report readiness shall report status of supply, equipment condition, personnel, and training. PWRM UICs that do not have personnel associated with the reporting PWRM UIC capability shall enter a "6" (not assessed) in the personnel and training portions of the readiness report.

(3) As the status of essential equipment alone may not always fully reflect the readiness of a PWRM set, a report's overall readiness assessment (i.e., C-rating) shall include the impact of the supply and operational readiness of non-essential equipment, as appropriate.

UNCLASSIFIED

CJCSI 4310.01E
25 November 2019

b. Title 10, U.S. Code, section 2229a requires DoD to annually report the status of pre-positioned materiel and equipment based on the fiscal year.

(1) The Joint Staff/J-4 shall coordinate with the Services and the CCDRs for the submission of the annual report to Congress.

(2) Services shall provide an update on the status of their pre-positioned capabilities programs on an annual basis. The Joint Staff/J-4 shall provide the format and submission times for the report.

(3) GCCs with OPLAN/CONPLAN PWRM requirements shall report the assumptions and shortfalls of Service PWRM positioned in their AOR. Additional information may require a mitigation strategy for any identified shortfalls.

(4) Mitigation of shortfalls will be coordinated between the GCC and the Services, with the Joint Staff assisting in bridging capability gaps and removing barriers pertaining to the readiness of operational and pre-positioned assets.

UNCLASSIFIED

CJCSI 4310.01E
25 November 2019

(INTENTIONALLY BLANK)

A-10

Enclosure A

UNCLASSIFIED

UNCLASSIFIED

CJCSI 4310.01E
25 November 2019

ENCLOSURE B

GUIDANCE FOR THE EMPLOYMENT OF PRE-POSITIONED WAR RESERVE MATERIEL

1. Background. This enclosure provides the administrative requirements, responsibilities, and procedures for using pre-positioning ships and the operational employment of associated PWRM-afloat and -ashore.

a. Pre-positioning Ships

(1) Pre-positioning ships provide the strategic positioning of materiel and capabilities available for GCC to respond to a full spectrum of global contingencies, as appropriately authorized by higher authority. They provide the CCDR greater flexibility by reducing early lift requirements and increased global responsiveness.

(2) Pre-positioning ships are assigned to the GCC by reference b. These ships are funded and stocked by specific Services using the appropriate Service's activity group and/or sub-activity group code for ship pre-positioning and surge.

(3) The Navy, through the Military Sealift Command (MSC), exercises administrative control (ADCON) over these ships (excluding PWRM-afloat), to include personnel management, readiness, maintenance, and other matters distinct from the operational mission as per reference h.

(4) MSC exercises ADCON in coordination with the Service that funds and/or stocks the ship and the GCCs to which these ships are assigned or attached.

b. PWRM-Afloat

(1) Materiel that is pre-positioned aboard pre-positioning ships facilitates rapid responsiveness to a GCC's AOR in support of a full spectrum of military operations that require specific equipment and/or supplies.

(2) Administrative operations include maintenance, restocking, reconstitution, stock change-out, theater security cooperation (TSC), training exercises, developmental/operational test and evaluation, and experimentation. To administratively employ PWRM-afloat for other than the normal care of supplies in storage and cyclic maintenance for equipment in storage, Services and Service component commands will coordinate with

UNCLASSIFIED

CJCSI 4310.01E
25 November 2019

affected GCC(s) and the Joint Staff. This coordination is done via a message that outlines the duration, quantities, types, scope of use, and plan to reconstitute the materiel.

(3) Services exercise ADCON over PWRM-afloat, per reference i, during administrative operations.

c. PWRM-Ashore

(1) To sustain a full spectrum of contingency operations until wartime lines of communication are established, materiel is strategically pre-positioned on land or near a theater of operations.

(2) Administrative operations include maintenance, restocking and reconstitution, stock change-out, TSC, training, developmental and operational test and evaluation, and experimentation. To administratively employ PWRM-ashore for other than the normal care of supplies in storage and cyclic maintenance for equipment in storage, Services and component commands will coordinate with affected GCC(s) and the Joint Staff. This coordination is done via a message that outlines the duration, quantities, types, scope of use, and plan to reconstitute the materiel.

(3) Services exercise ADCON over PWRM-ashore, per reference i, during administrative operations.

d. Assignment, Apportionment, Allocation, and Attachment of Pre-positioning Ships, PWRM-Afloat, and/or PWRM-Ashore

(1) Assigned Forces. A CCDR exercise Combatant Command (Command Authority) (COCOM) authority over pre-positioning ships that are assigned to them by the SecDef in accordance with reference b. As an assigned force, pre-positioning ships are available for steady state operations and may be organized and employed as the GCC determines necessary to accomplish assigned missions. PWRM-afloat (cargo, equipment, capabilities) is not assigned with specific ships.

(a) Assignment of pre-positioning ships with its associated PWRM-afloat does not constitute apportionment for planning nor allocation for execution.

(b) Assignment of pre-positioning ships is normally by quantity and/or ship type, vice identification of specific vessels.

UNCLASSIFIED

CJCSI 4310.01E
25 November 2019

(c) PWRM-ashore is positioned to support a GCC requirement in accordance with reference b.

(2) Apportioned Forces. Apportionment is for planning purposes and does not constitute assignment or allocation. Pre-positioning ships transporting PWRM-afloat may be apportioned, in accordance with reference b and i, for planning purposes to specific and/or multiple GCCs.

(a) A GCC exercises coordinating authority over pre-positioning ships that are apportioned, in accordance with references (b) and (j), to support their contingency plans. If essential agreement cannot be obtained, the matter is referred to the Joint Staff/J-4 for assistance.

(b) Apportionment of pre-positioning ships is normally by quantity and/or ship type, vice identification of specific vessels.

(c) PWRC provides the equipment and sustainment of an apportioned force structure to specific and/or multiple GCCs for planning in accordance with reference b.

(3) Allocated Materiel. Allocation is distributing limited resources among competing requirements for adaptive planning or actual employment. The President and/or the SecDef allocates pre-positioning ships, the associated PWRM-afloat, and/or PWRM-ashore usually through DEPORDs/EXORDs based on the allocation of the force using the PWRM.

(4) Reallocation of PWRM. Requests to reallocate PWRM are addressed to the CJCS, and coordinated through the Joint Staff/J-3 and J-4 for decision. Authority to operationally divert a pre-positioning ship from its previously assigned mission requires SecDef approval.

(5) Attached Forces. Attachment normally describes a force that has been temporarily transferred from a military department or CCMD to another CCMD. Pre-positioning ships may be attached to a CCMD other than the command to which they are assigned only by authority of the SecDef. Such attachment is typically accomplished via SecDef-approved DEPORD and EXORD.

2. Responsibilities

a. Joint Staff. Joint Staff/J-4 will:

(1) Assist the Navy and/or MSC, Services, and GCC in resolving above

UNCLASSIFIED

CJCSI 4310.01E
25 November 2019

issues, as required.

(2) Act as the point of contact for the Services and GCC on PWRM administrative and allocation issues. If required, refer critical allocation issues to the Joint Materiel Priorities and Allocation Board (JMPAB) for resolution in accordance with reference k.

(3) Provide oversight of the Service's PWRM programs for the on-hand and operational readiness of the equipment.

(4) Process requests and notification for the use of Service PWRC for operations and exercises.

(5) Coordinate with the Defense Logistics Agency (DLA) and the Services for the status of PWRS by geographical region.

b. Geographic Combatant Commanders

(1) Exercise COCOM over assigned pre-positioning ships.

(2) Exercise appropriate command authority over allocated or attached pre-positioning ships and/or PWRM in accordance with orders or guidance from higher authority; operationally employ or redeploy pre-positioning ships, as directed, to complete assigned missions.

(a) As directed by SecDef order (e.g., deployment or redeployment order), transfer pre-positioning ships and appropriate command authority to the Commander, U.S. Transportation Command (CDRUSTRANSCOM) to be part of the common user sealift pool (CUSP). PWRM may be partially or completely downloaded.

(b) As directed by SecDef order, transfer pre-positioning ships and appropriate command authority to another CCMD for other follow-on taskings for the ship, such as support for intra-theater logistics support, redeployment, reconstitution, and/or restocking.

(c) Absent direction to transfer to the CUSP or execute other mission taskings, the pre-positioning ship(s) remain under the authority of the CCMD to which it is assigned or attached.

(3) Issues regarding the allocation and reallocation of pre-positioning ships and/or associated PWRM-afloat are addressed to the CJCS for assistance; however, allocation authority is approved by the SecDef.

UNCLASSIFIED

UNCLASSIFIED

CJCSI 4310.01E
25 November 2019

(4) As mission requirements allow, make ships available for scheduled maintenance, training, reconstitution, and cargo loading, offloading, and/or reloading in accordance with coordinated schedules with the Navy and MSC and the requesting Service that has ADCON responsibilities for the materiel on the ship.

(5) When operational requirements exceed available PWRM resources, provide recommendations for redistribution in coordination with the appropriate Service(s) and the Joint Staff/J-3 and J-4.

(6) Refer to the Joint Staff/J-4 for assistance when maintenance, training, reconstitution, and cargo-loading requirement issues cannot be resolved through coordination with the Navy and MSC and/or the appropriate Service.

c. U.S. Transportation Command. USTRANSCOM will:

(1) Operationally employ, through MSC, pre-positioning ships that have been transferred to USTRANSCOM for inclusion in the CUSP.

(2) Return the pre-positioning ship from the CUSP to meet redeployment and/or reconstitution timelines as requested by the Service that provide the stocks to the ship and/or the GCC that exercises authority over the pre-positioning ship.

(a) If the requested CUSP return date conflicts with current tasking, USTRANSCOM will coordinate with the requesting Service and/or GCC to arrange an agreed-upon date.

(b) Issues regarding the return from CUSP that cannot be resolved after consultation with the appropriate Service and/or GCC should be referred to the Joint Staff/J-4 for assistance.

(3) As per the SecDef order, redeploy the pre-positioning ship to the GCC that deployed or exercises authority over the ship, once the CUSP mission or need for the ship is complete.

d. Navy and/or Military Sealift Command. The Navy, through the MSC, will:

(1) Staff, operate, and maintain the pre-positioning ship(s) to meet the requirements of the GCC to which a particular ship(s) is assigned, attached, or allocated.

UNCLASSIFIED

CJCSI 4310.01E
25 November 2019

(2) Determine ship maintenance requirements.

(3) Schedule and execute required maintenance and training for the ship(s) (as necessary) in consultation with the Service that provides and/or funds the PWRM, leases and/or owns the ship, and the affected GCC.

(4) Refer to the Joint Staff/J-4 for assistance when maintenance and training requirement issues cannot be resolved through coordinating efforts.

e. Services

(1) Exercise ADCON responsibilities in accordance with title 10, U.S. Code (reference i) authority over PWRM -afloat and -ashore.

(2) Coordinate, through Service component commands, with the appropriate CCMD on Service-specific programmatic concerns, activities, and/or events that affect the positioning or readiness of PWRM.

(3) Refer to the Joint Staff/J-4 for assistance when maintenance, training, reconstitution, stock change-out, and/or stock readiness issues cannot be resolved through consultation with the appropriate GCC.

(4) Determine and execute PWRM maintenance requirements.

(5) Determine and execute PWRM load and/or offload requirements.

(6) Determine ship berth and mooring locations in conjunction with MSC and the appropriate naval component command.

(7) Following the discharge of PWRM, the GCC may transfer the pre-positioning ship to USTRANSCOM (as part of CUSP). The Service that provided the PWRM is no longer responsible to fund common user costs associated with movement and/or positioning of the ship. While ships remain in CUSP, the applicable Service will retain responsibility for contracted ship per diem and operational costs not associated with CUSP-required transits.

(8) Schedule and execute required materiel loading, maintenance, and inter- and intra-theater materiel rotation (as necessary) in coordination with the affected GCC(s), naval component commands, and the MSC.

(9) When operational requirements exceed available PWRM resources, provide recommendations for redistribution of PWRM to the Joint Staff/J-3 and

UNCLASSIFIED

CJCSI 4310.01E
25 November 2019

J-4 in coordination with the appropriate GCC(s).

(10) Refer to the Joint Staff/J-4 for assistance when maintenance and training requirement issues cannot be resolved through coordination.

3. Procedures. The procedures listed below identify the operational procedures to assist the Services and GCC in executing the above responsibilities:

a. Operational Employment

(1) Employment Orders. Operation plans, OPORD, and/or contingency plans contain pre-positioning ships and PWRM for execution by an appropriate order (DEPORD or EXORD) from sufficient authority to employ the assets unless otherwise directed (Chart 3).

(a) A SecDef decision will normally come as part of a DEPORD or EXORD. Orders to employ and/or deploy pre-positioning ships may also come as part of a SecDef message to execute a functional plan.

(b) Employment outside the context of allocated forces contained in a TPFDD of an approved OPLAN, contingency plan, or OPORD for pre-positioning ships or PWRC will be requested via a Request for Forces (RFF) to the Joint Staff identifying the units or capabilities required. The SecDef-ordered force provider is required to ensure that the unit is manned, trained, and equipped to meet the CCMD requirements in the RFF. If required, the RFF may request that the unit or capability be equipped via the PWRM in theater; however, the force provider will ultimately determine if this is necessary.

Operational Employment of PWRM for Forces and Equipment

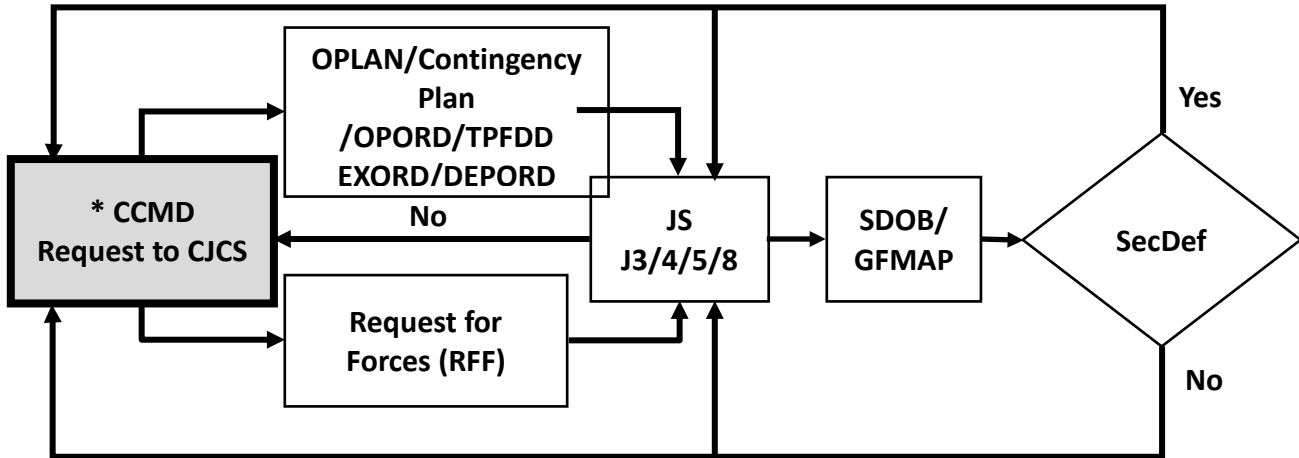

Chart 3

(c) Requests for only equipment will not be handled through the RFF process. Equipment-only requests are staffed through the Joint Staff for action and should originate as a memorandum to the Joint Staff J-4 (Chart 4). However, equipment only requests that do not affect other CCDRs require Service concurrence and notification to the Joint Staff J-4 with an associated reconstitution plan. This notification will contain the elements identified in Enclosure C.

(d) Requests for equipment-only, Military Department/Service augmentation, interagency, other governmental organizations, Coalition forces, contractors, and non-governmental organizations are not captured as part of the global demand on the U.S. military and will not be requested via the allocation process.

Operational Employment of PWRM for Equipment Only

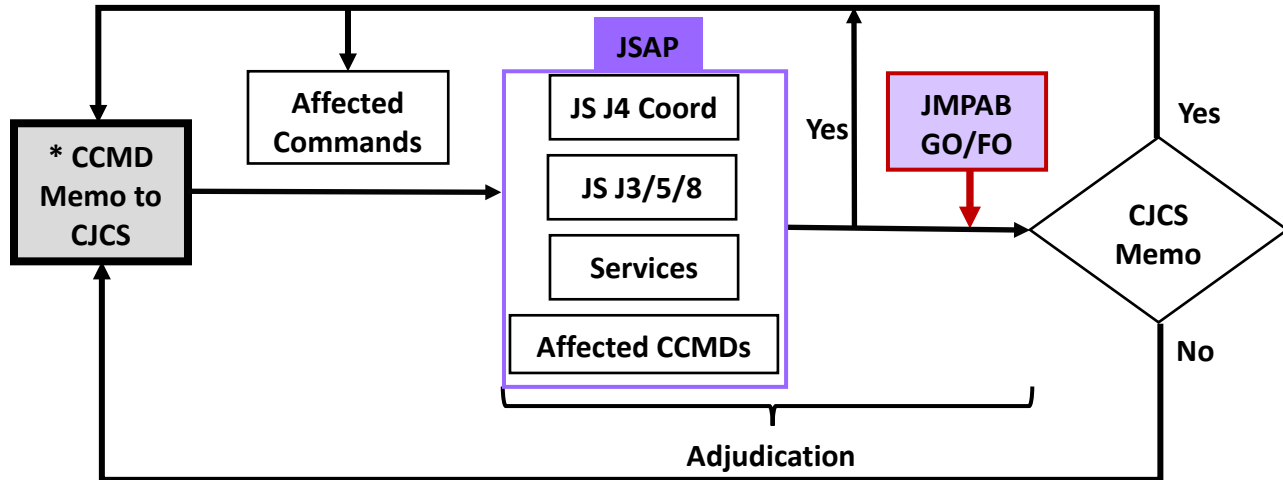

Chart 4

(2) Employment of PWRM. A CCMD requests authority within an RFF (see paragraph 3.a.(1)) if forces are included in the request. If the ordered force provider requires PWRM to provide a sourcing solution, SecDef approval for the employment of PWRM afloat or ashore (see paragraph 3.a.(1)(a)) will be transmitted via the GFMAP (a subcomponent /product of reference (b)). If the GCC or Service requests access to the operational employment of PWRM, SecDef approval is normally transmitted in the form of a DEPORD or EXORD. PWRM and pre-positioning ships included in an OPLAN/contingency plan/OPORD do not require an RFF. An EXORD for the OPLAN implies allocation of the assets and authority to employ.

(a) A GCC may consider apportioned forces with associated PWRM-ashore and/or -afloat during their adaptive planning processes.

(b) A GCC exercise coordinating authority over PWRM-ashore that is associated with apportioned forces in accordance with reference b.

(3) Employment of Pre-positioning Ships. Pre-positioning ships execute assigned missions under the command authority of the GCC in accordance with reference c or as designated in the SecDef-approved DEPORD and EXORDs. Command authority over a pre-positioning ship that has partial or complete discharge of its PWRM-afloat will be dictated by approved orders from higher authority. Options for command authority over the ship include:

UNCLASSIFIED

CJCSI 4310.01E
25 November 2019

- (a) Retention by the designated GCC for further use.
- (b) Transfer back to the GCC to which the ship is permanently assigned (if different from the command to which it is attached or allocated for employment).
- (c) Transfer to a GCC other than that to which previously attached or permanently assigned, to execute other missions or for reconstitution and/or restocking.
- (d) Transfer to CDRUSTRANSCOM for use in the CUSP.
- (e) Execute other taskings as directed by higher authority.
- (f) After completing all operational taskings, the ship's PWRM-afloat is normally restocked and/or reconstituted as described in paragraph 3.a.(4).

(4) CUSP Transfer, Redeployment, Restocking, and/or Reconstitution

(a) Normally, redeployment, restocking, reconstitution, and/or CUSP transfer guidance is included in a SecDef order that deploys the pre-positioning ship(s). Guidance may include:

1. Transfer to the CUSP. The employing GCC may be directed to transfer the ship(s) to the CUSP after its mission is complete. Transfer to the CUSP constitutes reassignment of the ship to USTRANSCOM.

2. Return from the CUSP and/or Redeployment. USTRANSCOM and/or the GCC may be directed to return the ship from the CUSP and/or redeploy the ship to its assigned CCMD (in accordance with reference c) by the SecDef (via deployment or redeployment order) after completing its CUSP and/or pre-positioning offload mission.

3. Restocking and/or Reconstitution. USTRANSCOM and/or the GCC may be directed to execute a restocking and/or reconstitution plan (in conjunction with redeployment and/or return of the ship from the CUSP).

(b) The Service responsible for the PWRM will coordinate redeployment, restocking, reconstitution, and/or return from CUSP plan with USTRANSCOM and/or MSC, affected GCC(s), and the Joint Staff/J-4.

1. The plan will be published via record message at least 30 days in advance or earlier.

UNCLASSIFIED

CJCSI 4310.01E
25 November 2019

2. MSC shall coordinate ship-scheduling details of the plan with the appropriate naval component commander(s).

(c) Issues involving redeployment, restocking, reconstitution, and/or return from the CUSP that cannot be resolved after coordination between Navy and/or MSC, appropriate Services, and affected GCC(s) should be referred to the Joint Staff/J-4 for assistance.

(5) Maintenance (PWRM or Vessel) and/or Stock Change-Out

(a) Maintenance and/or stock change-out schedules for the pre-positioning ship and/or its PWRM will be executed as follows:

1. The Service that provides the PWRM, in consultation with the Navy and/or MSC and the affected GCC(s), will schedule and execute required materiel maintenance and/or stock change-out.

a. Stock change-out issues that must be considered include, but are not limited to, significant increases in total net explosive weight (NEW) that may exceed limitations for the ship, port, and/or anchorage. NEW restrictions necessitate close coordination with MSC and the affected naval component commander.

b. To the greatest extent possible, materiel maintenance and/or stock change-out will be scheduled to coincide with ship's maintenance schedule.

c. Services should formally coordinate and publish PWRM maintenance schedules not later than (NLT) 90 days prior to the ship's departure from its current location. The schedule should be published via record message and addressed to the Navy and/or MSC, affected GCC(s), and the Joint Staff/J-3 and J-4.

d. If the PWRM maintenance is being conducted as part of an event separately coordinated and/or scheduled by the MSC and/or GCC, then the provisions of subparagraph 3.a.(5)(a)1. are not necessary.

e. Maintenance and/or PWRM change-out issues that cannot be resolved after consultation with the Navy, MSC, and/or affected GCC(s) should be referred to the Joint Staff/J-4 for assistance.

2. Navy and/or MSC, in consultation with the Service that provides the PWRM and the affected GCC(s), will schedule and execute

UNCLASSIFIED

CJCSI 4310.01E
25 November 2019

required maintenance and training for the ship.

a. To the greatest extent possible, ship's maintenance will be scheduled to coincide with PWRM maintenance.

b. Navy and/or MSC should formally coordinate and publish ship maintenance schedules NLT 90 days prior to ship(s) departure from its current location. Ship maintenance schedules should be published via record message, addressed to the Service responsible for the PWRM, affected GCC(s), and the Joint Staff/J-4.

c. If the ship's maintenance is being conducted as a part of an event separately coordinated and/or scheduled by a Service or GCC, then the provisions of subparagraph 3.c.(1)(b)2. are not necessary.

d. Maintenance and training requirement issues that cannot be resolved after consultation with the appropriate Service and/or affected GCC(s) should be referred to the Joint Staff/J-4 for assistance.

(b) Scheduling and/or execution of maintenance and/or materiel change-out does not alter the GCC assignment of the ship or continuing COCOM that the GCC (as designated in reference c) maintains over the pre-positioning ship.

b. Program modification

(1) Temporary or Permanently Repositioning Pre-positioning Ships and/or associated PWRM

(a) Requests to temporarily or permanently change berthing location of pre-positioning ships will be coordinated among the Navy and/or MSC, Service responsible for the PWRM, affected GCC(s) and the Joint Staff (Chart 5).

1. Issues that must be considered include, but are not limited to, NEW restrictions for the port and/or anchorage.

2. MSC and the GCC (through its naval component commander) will determine the feasibility of a port and/or anchorage to support relocation and/or the need for waivers.

(b) After coordination, the Service component will request the berthing location change to the GCC. The GCC provides notification via

UNCLASSIFIED

CJCSI 4310.01E
25 November 2019

memorandum (Enclosure D) to the Joint Staff who will ensure official coordination is complete via Joint Staff Action Process and inform other affected command(s) for review and/or approval.

(c) The Director of Logistics, Joint Staff J-4, will concur with the request or, if he/she does not concur, he/she will forward the request to the CJCS for decision. Once a decision is made, a memorandum will be sent to the requesting GCC and the Service HQ.

Assignment Modification of Pre-positioning Ship (Temporary or Permanent)

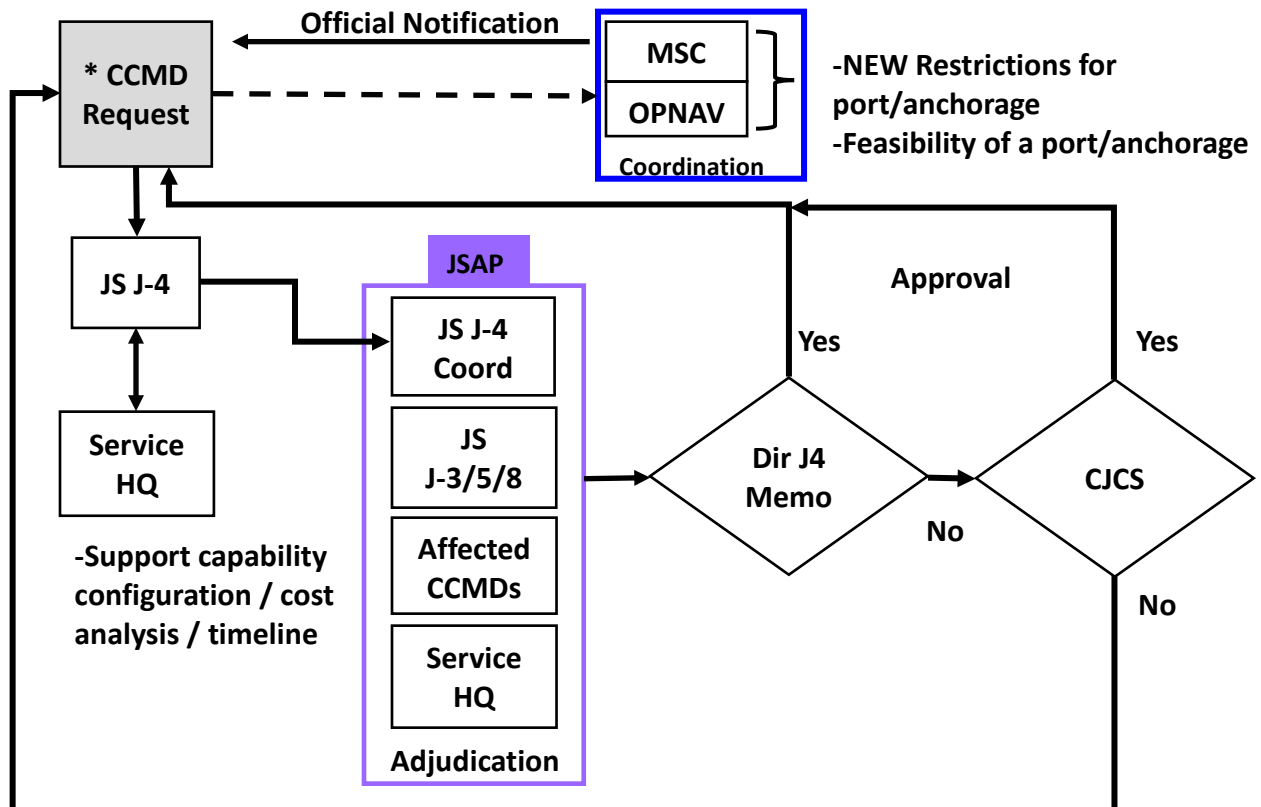

Chart 5

(2) Modification of Service PWRM Programs

(a) Chart 6 identifies the process Services shall use to notify the Joint Staff J-4 on the Service's intention to modify a PWRM program. Modification of a program is the removal or addition of a capability that supports the OPLAN/CONPLAN. The Service will initiate the modification by submitting a memorandum to the Joint Staff J-4 (Enclosure E).

UNCLASSIFIED

CJCSI 4310.01E
25 November 2019

(b) The Joint Staff shall coordinate internally as well as with affected GCC on the operational risk or mitigation pertaining to the modification.

(c) The Director of Logistics, Joint Staff J-4, will concur with the request or, if he/she does not concur, he/she will forward the request to the CJCS for decision. The Joint Staff J-4 memorandum to the CJCS shall include an assessment of the operational risk with the CCDR's or Service's mitigation strategy. Following the decision, the requesting CCDR and the Service HQ will receive notification via a memorandum from the Joint Staff.

(d) Modification to a Service PWRC does not include modernization of equipment or change to a program resulting from force structure changes.

(e) Modification shall include a timeline and justification for conducting the modification to the PWRM program.

Modification of Service PWRM Programs*

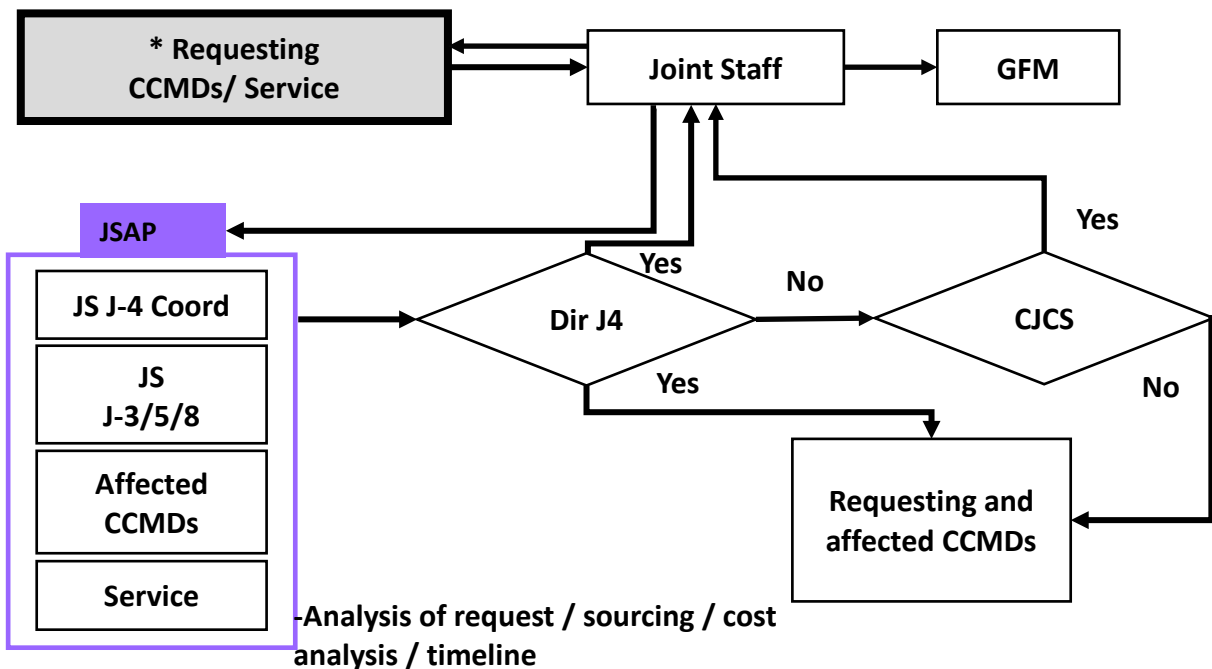

Chart 6

*Modification does not include modernization.

UNCLASSIFIED

CJCSI 4310.01E
25 November 2019

c. Training and/or Exercises

(1) Use of PWRM ashore and afloat for training and/or exercises shall be coordinated with the Service, affected GCC(s), and the Joint Staff (see Chart 7).

(2) The notification for the use of PWRM for training will include the amount of PWRM to be drawn, timeline for the use of the PWRM, and the reconstitution plan. The notification may be via a memo or an official message (Enclosure F).

(a) PWRM ashore used for training.

1. The use of PWRM ashore for training and/or exercises shall be coordinated with the appropriate Service, affected GCC(s), and Joint Staff.

2. Training or exercise issues for PWRM ashore that cannot be resolved with the appropriate Service and affected GCC(s) should be referred to the Joint Staff for assistance.

(b) PWRM afloat used for training.

1. The use of PWRM afloat for training and/or exercises shall be coordinated among Navy and/or MSC, the appropriate Service, affected GCC(s), and Joint Staff.

2. Participation in training or an exercise does not alter the assignment of a pre-positioning ship COCOM that the GCC (as designated in reference c) exercises over assigned pre-positioning ships, or the apportionment of the ship(s) for adaptive planning, per reference b.

3. Training or exercise issues for PWRM afloat that cannot be resolved after coordination among the Navy and/or MSC, appropriate Service and affected GCC(s), should be referred to the Joint Staff for assistance.

(3) Following the training or exercise, the Service will provide a status update of the reconstitution of the PWRM used for training to the Joint Staff J-4. This may include a timeline for full reconstitution, as required.

Training and Exercise Requirement

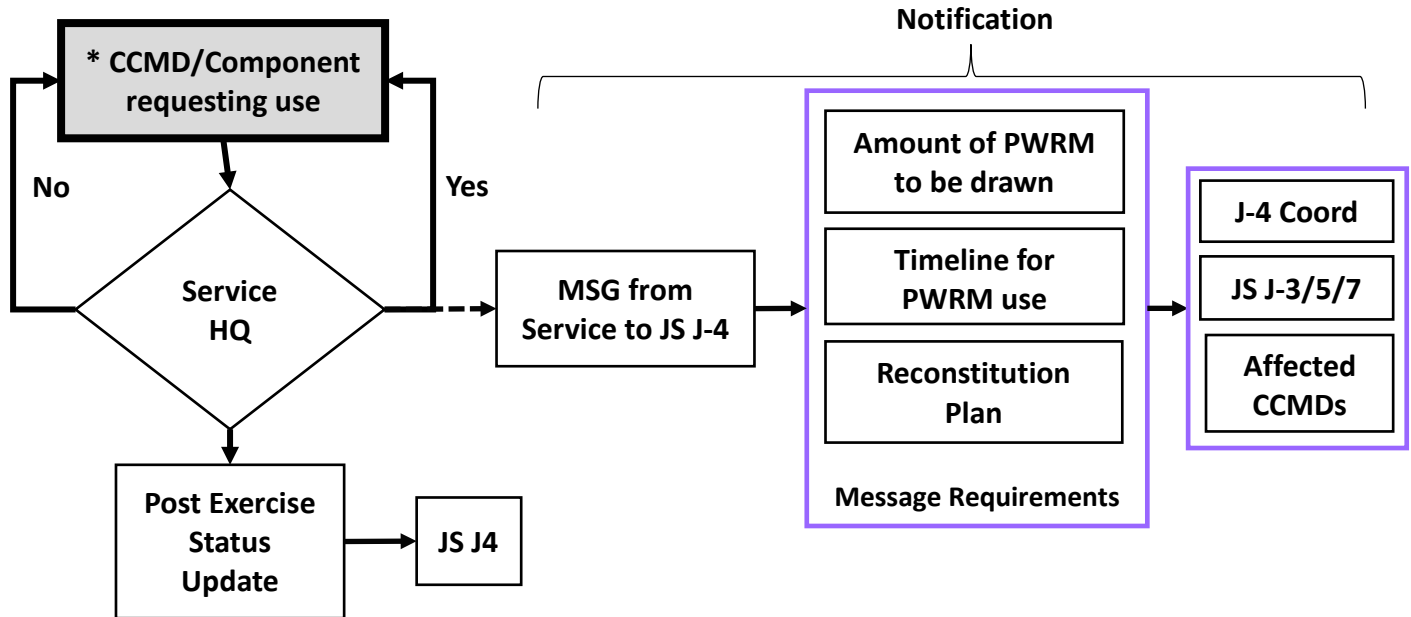

Chart 7

UNCLASSIFIED

CJCSI 4310.01E
25 November 2019

Summarization of the PWRM Release Process

| Request Type | Authority | Coordination | Remarks |
|---|-------------------------------|------------------------------------|---|
| New Requirements in Existing Location | Service | J4/J5/Affected CCMDS/OSD-Policy | Analysis of request/sourcing/cost analysis/timeline |
| New Requirement in New Location | SECDEF | J4/J5/OSD Policy/Embassy | Senior Governing Body (GPEC, OPSDEPS, JCS Tank, DMAG) |
| Operational Employment for Forces and PWRM | SECDEF | J3/J4/J5/J8 | SDOB/GFMAP |
| Operational Employment of PWRM Equipment "Only" | Requires JS J4 concurrence | J3/J4/J5/J8/Affected CCMDS | DJ4 Memo |
| Assignment Modification of Prepositioned Ships (Temp or Perm) | Requires JS J4 concurrence | J3/J4/J5/J8/Affected CCMDS | DJ4 Memo |
| Modification of Service PWRM Programs | Requires JS J4 concurrence | J3/J4/J5/J8/Affected CCMDS | DJ4 Memo |
| Training and Exercise Requirements | Service w/ JS J4 notification | J3/J4/J5/J7/CCMDS | Reconstitution Plan |

UNCLASSIFIED

CJCSI 4310.01E
25 November 2019

(INTENTIONALLY BLANK)

UNCLASSIFIED

UNCLASSIFIED

CJCSI 4310.01E
25 November 2019

ENCLOSURE C

MEMORANDUM FOR THE OPERATIONAL EMPLOYMENT OF EQUIPMENT

GEOGRAPHIC COMBATANT COMMAND OR SERVICE MEMORANDUM

MEMORANDUM FOR DIRECTOR FOR LOGISTICS, JOINT STAFF J-4

SUBJECT: (U) OPERATIONAL EMPLOYMENT OF EQUIPMENT FROM (*PWRM PROGRAM*)

1. In accordance with CJCSI 4310.01E Logistics Planning Guidance for Pre-positioned War Reserve Materiel, request the equipment listed in (*attachment listing all equipment to employ*) in support of Operation (_____).
2. *Provide justification of this request, risks pertaining to this repositioning, and mitigation strategy to address the risks. Additionally, provide a summary of anticipated duration of the request.*
3. *Service plan to reconstitute the equipment used from the PWRM program.*
4. *Identify the coordination the GCC made. Include attachments of the official documentation from the component/MS.*
5. The (GCC) J4 point of contact is (*PWRM/J4 Representative*).

GCC GO/FO Signature
Rank, Service
Billet, Section

UNCLASSIFIED

CJCSI 4310.01E
25 November 2019

(INTENTIONALLY BLANK)

UNCLASSIFIED

UNCLASSIFIED

CJCSI 4310.01E
25 November 2019

ENCLOSURE D

MEMORANDUM FOR THE REASSIGNMENT OF PRE-POSITIONING SHIP(S)

GEOGRAPHIC COMBATANT COMMAND OR SERVICE MEMORANDUM

MEMORANDUM FOR DIRECTOR FOR LOGISTICS, JOINT STAFF J-4

SUBJECT: (U) REASSIGNMENT OF (*PRE-POSITIONING SHIP*)

1. In accordance with CJCSI 4310.01E Logistics Planning Guidance for Pre-positioned War Reserve Materiel, request to reassign (*pre-positioning ships*) from (*location*) to (*location*).
2. *Provide justification of this request, risks pertaining to this repositioning, and mitigation strategy to address the risks. Additionally, provide a summary of MSC assessment for the Net Explosive Weight restrictions (if applicable), port/anchorage feasibility, and potential waiver.*
3. Service plans to conduct this reassignment during the execution of Maritime Pre-positioning Maintenance Cycles XX and XX.
4. *Identify any additional cost associated with the reassignment and plan to mitigate the costs.*
5. *Identify the coordination the GCC made. Include attachments of the official documentation from the component/MS.*
6. The (GCC) J4 point of contact is (*PWRM/J4 Representative*).

*GCC GO/FO Signature
Rank, Service
Billet, Section*

UNCLASSIFIED

UNCLASSIFIED

CJCSI 4310.01E
25 November 2019

(INTENTIONALLY BLANK)

UNCLASSIFIED

UNCLASSIFIED

CJCSI 4310.01E
25 November 2019

ENCLOSURE E

MEMORANDUM FOR THE MODIFICATION OF A SERVICE PWRM PROGRAM GEOGRAPHIC COMBATANT COMMAND OR SERVICE MEMORANDUM

MEMORANDUM FOR DIRECTOR FOR LOGISTICS, JOINT STAFF J-4

SUBJECT: (U) MODIFICATION OF (*PWRM PROGRAM*)

1. In accordance with CJCSI 4310.01E Logistics Planning Guidance for Pre-positioned War Reserve Materiel, request to modify (*PWRM Program*) at (*location*).
2. *Provide justification of this request, risks pertaining to the modification of the PWRM program and mitigation strategy to address the risks. Additionally, provide a summary of the modification to the program (this does not include modernization of the program).*
3. Service plans to conduct this modification during (*FY-XX*).
4. *Identify any additional cost or cost savings associated with the program modification and plan to mitigate the costs.*
5. *Identify the coordination the GCC made. Include attachments of the official documentation from the component/MS.*
6. The (*GCC*) J4 point of contact is (*PWRM/J4 Representative*).

GCC GO/FO Signature
Rank, Service
Billet, Section

UNCLASSIFIED

CJCSI 4310.01E
25 November 2019

(INTENTIONALLY BLANK)

UNCLASSIFIED

UNCLASSIFIED

CJCSI 4310.01E
25 November 2019

ENCLOSURE F

MESSAGE FORMAT FOR USE OF PRE-POSITIONED WAR RESERVE MATERIEL FOR TRAINING/EXERCISES

(CLASSIFICATION)

FM

TO

INFO

UNCLAS

SUBJ/AUTHORIZATION TO USE PREPOSITIONED WAR RESERVE MATERIEL FOR
EXERCISE _____FROM (PWRM PROGRAM LOCATION)//

REF/A/MSG/000000Z MON YR/COMPONENT/
REF/B/CJCSI 4310.01//

NARR/REF A IS COMPONENT REQ TO USE PWRM FOR EXERCISE _____ FROM
(DATE) TO (DATE)/REF B IS LOGISTICS PLANNING GUIDANCE FOR
PREPOSITIONED WAR RESERVE MATERIEL//

POC/NAME/RANK/UNIT/TELEPHONE/E-MAIL//

GENTEXT/REMARKS/1. THE REQUEST CONTAINED IN REF A IS APPROVED AS NOTED
BELOW.

1.A. USE OF SUSTAINMENT FROM (LOCATION)_____ IS AUTHORIZED AS
FOLLOWS.

READ IN FOUR COLUMNS:

| COS | DESCRIPTION | %REQUESTED | %AUTH |
|-----|-------------------------|------------|-------|
| I | MEALS READY TO EAT | 33% | 33% |
| III | PACKAGE POL | 100% | 100% |
| IV | CONSTR/BARRIER MATERIAL | 75% | 75% |
| V | AMMO | 20% | 20% |
| IX | REPAIR PARTS | 100% | 100% |

2. PRINCIPAL END ITEMS (PEIS)

2.A. REQUESTED EQUIPMENT WILL BE TEMP ISSUED TO THE EXERCISE FORCE
PER REF B.

2.B. PRIOR TO INITIAL ISSUE OF THE PEIS, A JLTJ WILL BE CONDUCTED
BETWEEN _____ AND THE EXERCISE FORCE. UPON COMPLETION OF

F-1

Enclosure F

UNCLASSIFIED

UNCLASSIFIED

CJCSI 4310.01E
25 November 2019

JLTI, ALL PEIS WILL BE TEMP-LOANED TO THE EXERCISE FORCE RESPONSIBLE OFFICER, AND WILL REMAIN IN A TEMP LOAN STATUS FOR THE DURATION OF EXERCISE. A TURN-IN JLTI WILL BE CONDUCTED UPON COMPLETION OF EXERCISE.

3. CLASS I. FOR PLANNED CONSUMPTION OF MRES, REIMBURSEMENT TO DLA MUST BE COORDINATED WITH (SERVICE HEADQUARTERS) FOOD SERVICE SECTION.

4. CLASS V. THE FOLLOWING GUIDANCE IS PROVIDED:

4.A. ALL AMMUNITION DRAWN FROM _____ PREPOSITIONING OBJECTIVE (PO) STOCKS SHALL NO MORE THAN 20 PERCENT OF THE QUANTITIES OF EACH DODIC. THEREFORE, ALL REQUISITIONS ABOVE THAT THRESHOLD ARE REDUCED FOR ISSUE.

4.B. ALL AMMUNITION DRAWN FROM PO STOCKS MUST BE WITHIN THE UNIT'S ANNUAL TRAINING ALLOCATION, AND WILL BE COUNTED AGAINST THE USING UNIT'S ANNUAL TRAINING ALLOWANCE IN TOTAL AMMUNITION MANAGEMENT INFORMATION SYSTEM (TAMIS). IF REQUESTED QUANTITIES ARE NOT IN THE EXERCISE FORCE'S ANNUAL TRAINING ALLOCATION, NO AMMUNITION WILL BE ISSUED.

4.C. ALL UNEXPENDED AMMUNITION THAT HAS BEEN BROKEN OPEN FROM ITS ORIGINAL PACKAGING MUST BE PROPERLY RE-PACKAGED PRIOR TO RETURNING TO THE USNS _____. RESPONSIBILITY FOR RE-PACKAGING, TO INCLUDE USE OF PROPER PACKING MATERIALS, LIES WITH THE EXERCISE FORCE.

4.D. EXERCISE FORCE MUST PROVIDE (SERVICE PWRM MANAGEMENT ORGANIZATION) OPERATIONS AN E-581 FROM TAMIS AND NAVMC 11797 DELEGATION OF AUTHORITY NLT (DATE) IOT SUPPORT AMMUNITION REQUIREMENTS.

5. TASKS

5.A. (SERVICE COMPONENT)

5.A.1. ENSURE THAT A REPORT ON LESSONS LEARNED SPECIFIC TO THE USE OF PWRM FROM (EQUIPMENT LOCATION) IN SUPPORT OF EXERCISE _____ IS SUBMITTED TO THE SERVICE LESSONS LEARNED ORGANIZATION (EMAIL). REPORT IS DUE NLT 45 DAYS AFTER COMPLETION OF THE EXERCISE.

5.A.2. ENSURE ALL EQUIPMENT USED DURING EXERCISE IS RETURNED TO PRE-EXERCISE CONDITION.

5.A.3. PROVIDE SECURITY, MAINTENANCE, AND ACCOUNTABILITY FOR ALL ASSETS.

UNCLASSIFIED

CJCSI 4310.01E
25 November 2019

5.A.4. EXERCISE FORCE IS RESPONSIBLE FOR ALL COSTS RELATED TO REPAIR OR REPLACEMENT OF DAMAGED OR LOST EQUIPMENT. PROVIDE COST JON FOR REPAIR AND MAINTENANCE TO (SERVICE HEADQUARTERS).

5.A.5. COORDINATE WITH CG (PWRM MANAGEMENT OFFICE) FOR TECHNICAL ASSISTANCE AND ADVISORY SUPPORT.

5.A.6. COORDINATE WITH CG (PWRM MANAGEMENT OFFICE) FOR REQUESTED SUPPORT.

5.A.7. IDENTIFY A RESPONSIBLE OFFICER (RO) AND PROVIDE COPY OF THE RO APPOINTMENT LETTER TO (SERVICE PROCESS ON EQUIPMENT ACCOUNTABILITY).

5.A.8. INITIATE AN OPERATIONAL BUDGET TRANSFER TO CG (PWRM MANAGEMENT OFFICE) NLT 30 DAYS AFTER COMPLETION OF EXERCISE, FOR REIMBURSEMENT OF SUPPLIES/SUPPORT USED.

5.B. CG (PWRM MANAGEMENT OFFICE)

5.B.1. COORDINATE WITH (SERVICE COMPONENT) AS REQUIRED.

5.B.2. PROVIDE TECHNICAL ASSISTANCE ADVISORY TEAM SUPPORT.

5.B.3. CAPTURE ALL EXPENDITURES WHERE XXXX FUNDING IS USED AND PROVIDE DETAILED REPORT SHOWING AMOUNTS AND PURPOSE OF EXPENDITURE TO SERVICE HEADQUARTERS NLT 30 DAYS AFTER END OF EXERCISE IOT TO FACILITATE POSSIBLE REIMBURSEMENT.

5.B.4. PROVIDE (LOCATION)_____ REPLENISHMENT REPORT TO (SERVICE HEADQUARTERS) VIA AMHS MESSAGE EVERY 30 DAYS AFTER COMPLETION OF EXERCISE CONCERNING STATUS OF REPLENISHMENT CONSUMABLES/SECONDARY REPARABLES. REPORT WILL CONTINUE UNTIL (LOCATION OF PWRM) _____ IS FULLY REPLENISHED.

6. DIRLAUTH.//

UNCLASSIFIED

CJCSI 4310.01E
25 November 2019

(INTENTIONALLY BLANK)

UNCLASSIFIED

UNCLASSIFIED

CJCSI 4310.01E
25 November 2019

ENCLOSURE G

REFERENCES

- a. Joint Publication 1, w/CH 1, 12 July 2017, "Department of Defense Dictionary of Military and Associated Terms"
- b. Global Force Management Implementation Guidance
- c. Unified Command Plan, 3 November 2017
- d. CJCSI 3401.02 Series, "Force Readiness Reporting"
- e. DoDD 7730.65, 11 May 2015, "Department of Defense Readiness Reporting System (DRRS)" (with Change 1 dated 31 May 18)
- f. DoDD 7730.66, 8 July 2011, "Guidance for the Defense Readiness Reporting System (DRRS)"
- g. CJCSI 2300.02 Series, "Coordination of Overseas Force Structure Changes and Host-Nation Notification"
- h. Joint Publication 4-01.2, 29 December 2015, "Sealift Support to Joint Operations"
- i. Title 10, U.S. Code, Subtitle A, Part I, Chapter 6, "Combatant Commands"
- j. CJCSI 3110.03 Series, "Logistics Supplement to the Joint Strategic Capabilities Plan"
- k. CJCSI 4120.01 Series, "Transportation Movement Priority System"

Other Relevant Doctrinal/Instructional Documents

1. DoDI 3110.06, 7 January 2019, "War Reserve Materiel Policy"
2. JP 4-0, 4 February 2019, "Joint Logistics"

UNCLASSIFIED

CJCSI 4310.01E
25 November 2019

(INTENTIONALLY BLANK)

G-2

Enclosure G

UNCLASSIFIED

UNCLASSIFIED

CJCSI 4310.01E
25 November 2019

GLOSSARY

PART I-ABBREVIATIONS AND ACRONYMS

Items marked with an asterisk () have definitions in PART II*

| | |
|---------------|--|
| ADCON | administrative control (authority) |
| AOR | area of responsibility |
| CCMD | Combatant Command |
| CCDR | Combatant Commander |
| CDRUSTRANSCOM | Commander, United States Transportation Command |
| COCOM | Combatant Command (command authority) |
| CONUS | continental United States |
| CUSP | common user sealift pool |
| DEPOD | deployment order |
| DoD | Department of Defense |
| DPG | defense planning guidance |
| DRRS | DoD readiness reporting system |
| EXORD | execute order |
| FUNCPLAN | functional plan |
| GCC | geographic Combatant Commander |
| GFMAP | Global Force Management Allocation Plan |
| GMIG | Global Force Management Implementation Guidance |
| GO/FO | General Officer/Flag Officer |
| HNN | host nation notification |
| J-3 | operations directorate of a joint staff |
| J-4 | logistics directorate of a joint staff |
| J-5 | strategic plans and policy directorate of a joint staff |
| J-7 | operational plans and joint force development directorate of a joint staff |
| J-8 | force structure, resources, and assessment directorate of a joint staff |
| JMPAB | Joint Materiel Priorities and Allocation Board* |

UNCLASSIFIED

CJCSI 4310.01E
25 November 2019

| | |
|-------------|--|
| JSCP | Joint Strategic Capabilities Plan |
| MSC | Military Sealift Command |
| NDAA | national defense authorization act |
| NEW | net explosive weight |
| NMS | national military strategy |
| NSS | national security strategy |
| OFSC | overseas force structure change |
| OPLAN | operational plan |
| OPNAV | Chief of Naval Operations |
| OPORD | operation order |
| PWRC | pre-positioned war reserve capabilities* |
| PWRM | pre-positioned war reserve materiel* |
| PWRM-afloat | pre-positioned war reserve materiel-afloat |
| PWRM-ashore | pre-positioned war reserve materiel-ashore |
| PWRR | pre-positioned war reserve requirement* |
| PWRS | pre-positioned war reserve stocks* |
| RFF | request for forces |
| SecDef | Secretary of Defense |
| TDP | theater distribution plan |
| TPFDD | time phased force and deployment data |
| TSC | theater security cooperation |
| USTRANSCOM | U.S. Transportation Command |

UNCLASSIFIED

CJCSI 4310.01E
25 November 2019

PART II-DEFINITIONS

(Unless otherwise referenced, terms and definitions are sourced to this document only)

Allocated — Distribution of limited forces and resources for employment among competing requirements. Those forces, individuals, and resources provided by the President or Secretary of Defense to a Combatant Commander, not already assigned to that Combatant Commander for execution. (GFMIG 2019–2020, JP 5-0)

Allocation — Supplements a unified commander’s assigned force through the temporary transfer of forces and individuals to Combatant Commanders in a prioritized and risk informed manner. Forces are allocated to meet the Secretary of Defense’s strategic priorities and the Combatant Commander operational requirements. When allocating a force, the Secretary of Defense specifies the command relationship (e.g., operational control or tactical control) the Combatant Commander assumes over the force as well as the duration, authorized missions, location, and other instructions. The Secretary of Defense communicates his direction to allocate forces in an order called the GFM Allocation Plan. (GFMIG 2019–2020)

Apportioned — Those forces and resources a Combatant Commander can reasonably expect a service to be able to deploy, but not necessarily an identification of the actual forces/units that will be allocated for use when a contingency plan or crisis response plan transitions to execution. The apportionment of a force does not authorize or establish command relationships. (GFMIG 2019–2020, JP 5-0)

Assigned — Those forces and resources, which have been placed under the Combatant Command authority of a unified commander by direction of the Secretary of Defense in his Forces for Unified Commands Memorandum in accordance with title 10, U.S. Code, section 162. To place units or personnel in an organization where such placement is relatively permanent, and/or where such organization controls and administers the units or personnel for the primary function, or greater portion of the functions, of the unit or personnel. (GFMIG 2019-2020, JP 3-0, DoD Dictionary)

Consultation — The method by which two or more departments, forces, and/or components advise each other of a special function and/or activity. For the purposes of this instruction, “consultation” does not in itself compel or indicate agreement.

UNCLASSIFIED

CJCSI 4310.01E
25 November 2019

Coordination — The method by which two or more departments, forces, and/or components bring into common action special functions and/or activities. The commander or individual exercising coordinating authority has the authority to require consultation between the agencies involved, but does not have the authority to compel agreement.

Joint Materiel Priorities and Allocation Board — A board that establishes, modifies, and/or recommends priorities for allocation of critical materiel assets in the DoD distribution system for the fulfillment of logistics requirements (all classes of supply) of U.S., allied, and/or coalition forces for approval by the Chairman of the Joint Chiefs of Staff.

Pre-positioned War Reserve Capabilities (PWRC) — Unit type sets of equipment and stocks (ashore and afloat) strategically positioned to provide a warfighting capable force to the Geographic Combatant Command.

Pre-positioned War Reserve Materiel (PWRM) — War reserve materiel strategically located to facilitate a timely response in support of Combatant Commander requirements during the initial phases of an operation.

Pre-positioned War Reserve Requirement (PWRR) — Material identified as requirement in Secretary of Defense planning guidance to be pre-positioned at or near the point of planned use to reduce reaction time and to ensure adequate support of military forces during early stages of war until stock can be replenished.

Pre-positioned War Reserve Stocks (PWRS) — Stockpiles of materiel strategically positioned that provides sustainment to the capabilities or materiel supporting military operations.

Starter Stock — War reserve material stocks pre-positioned in or near a theater of operations to last until resupply at wartime rates is established.

Swing Stock — War reserve material stocks positioned ashore or afloat for meeting WRM requirements of more than one contingency in more than one theater or operation.